

STAMBENI OBJEKAT P+1+Pk

# ČETVOROSOBAN STAN B3 POTKROVLJE: 114,93m<sup>2</sup>

# EURAMONT

## Položaj stana na osnovi sprata

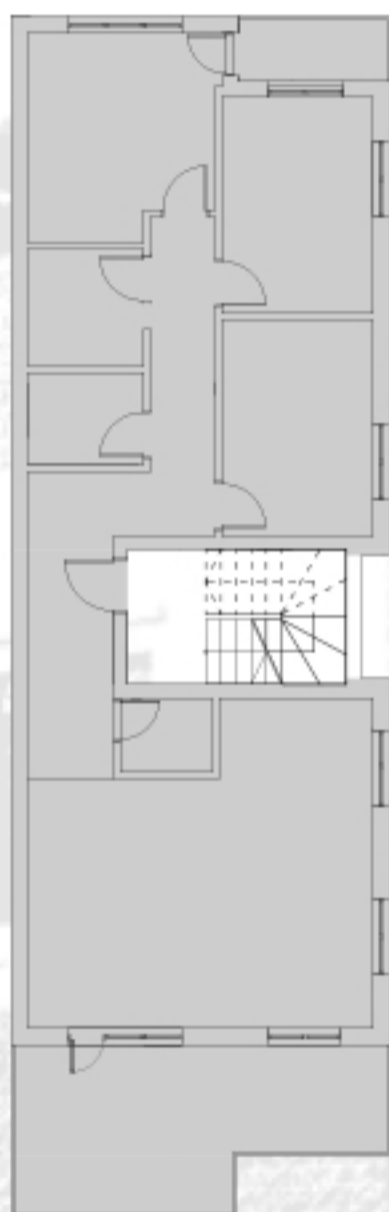

Ul. Branka Vukosavljevića

## 3D izgled stana



Uz četvorosoban stan - privatna krovna terasa od 100 kvadrata

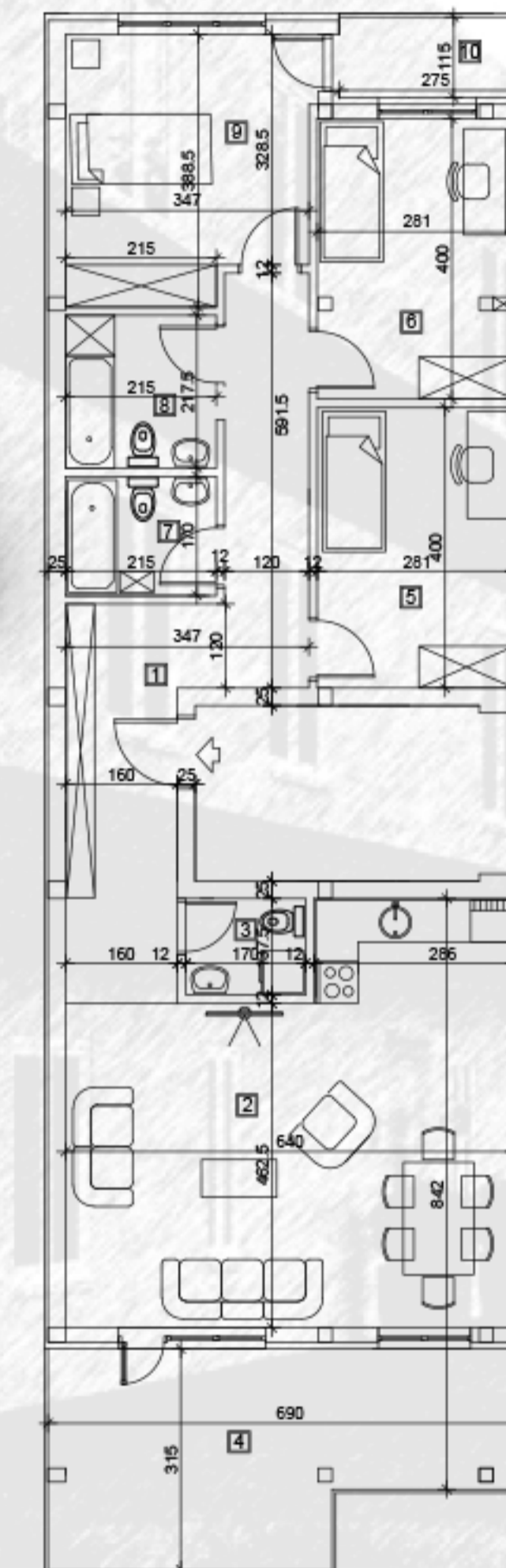

## SPECIFIKACIJA POVRŠINA

### STAN 3 (POTKROVLJE)

br.	namena	obrada poda	P(m <sup>2</sup> ) 100%	P(m <sup>2</sup> ) 97%
1	ULAZNI HODNIK	parket	17,02	16,51
2	DNEVNA SOBA SA KUHINJOM I TRPEZARIOM	parket/keram. pločice	33,87	32,85
3	WC	keram.pločice	2,34	2,27
4	TERASA	keram. pločice	18,46	17,91
5	SOBA	parket	11,24	10,90
6	SOBA	parket	11,24	10,90
7	KUPATILO	keram. pločice	3,66	3,66
8	KUPATILO	keram.pločice	4,67	4,53
9	SPAVAĆA SOBA	parket	12,82	12,44
10	TERASA	keram.pločice	3,16	3,07
<b>UKUPNO NETO</b>			<b>118,48</b>	<b>114,93</b>

## RASPOLOŽIVOST NEKRETNINE

STAN B3: \_\_\_\_\_